

RAC type

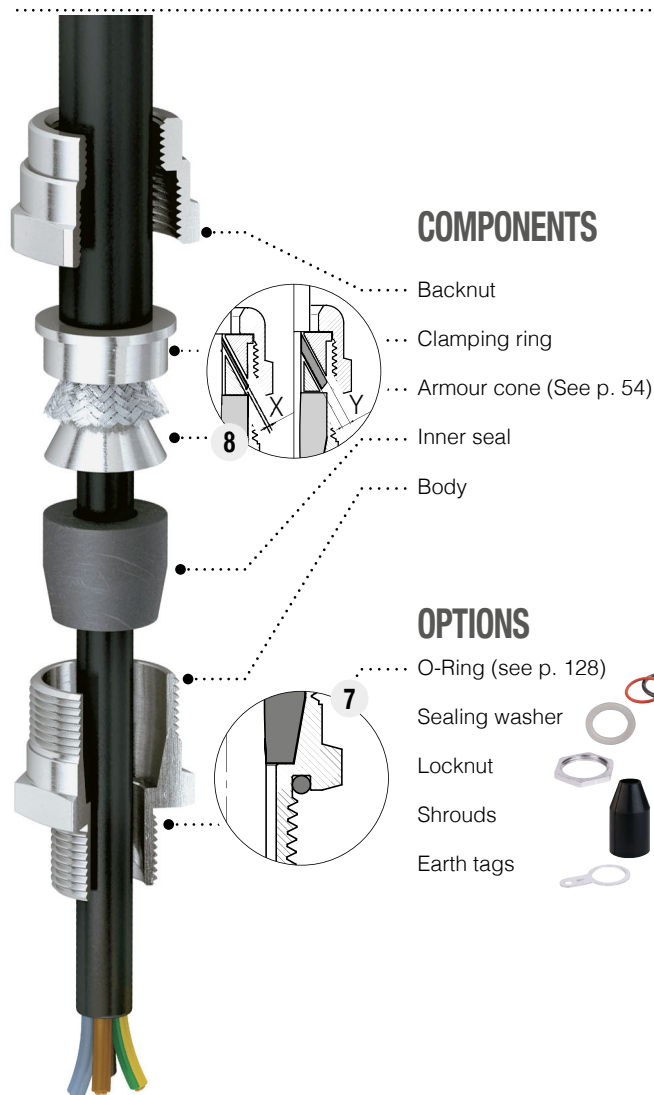

FLAMEPROOF EX D • INCREASED SAFETY EX E • FOR INDOOR & OUTDOOR APPLICATIONS
FOR ARMoured CABLES • UNDER ARMOUR SHEATH SEALING



COMPONENTS

- Backnut
- Clamping ring
- Armour cone (See p. 54)
- Inner seal
- Body

OPTIONS

- O-Ring (see p. 128)
- Sealing washer
- Locknut
- Shrouds
- Earth tags

1 Cable glands RAC type (code: RAC)

The sealing ring blocks the cable on the diameter under armour. The cone rings grips and grounds the cable armour. The addition of female thread on the backnut allows the cable gland to be coupled to a conduit fitting. Cable glands EMC tested by triaxial method, according to IEC 62153-4-3, IEC 62153-4-4 standards. Metric cable glands are made according to EN 62444 standard. Maintenance and installation operations and product selection must be done in accordance with IEC EN 60079-14 and 17 standards.

Application fields Surface - Group II • Mines - Group I

Approvals / Certifications

ATEX INERIS 06 ATEX 0014X
 IEC Ex: IEC Ex INE 10.0010X
 EAC: RU C-IT.АЯ 45.В.00909
 Type examination certificate: INERIS 17 ATEX 3009X (Ex nR IIC Gc)

Protection type

Ex db IIC • Ex eb II (gas) • Ex tb IIIC (dusts) • Ex db I • Ex eb I (mines)

EPL (Equipment protection level)

Zone 1-2: Mb mines • Gb, Gc gas
Zone 21-22: Db Dc combustible dusts

Execution

Ex db IIC • Ex eb II • Ex tb IIIC • Ex db I • Ex eb I Db
 according to
ATEX: EN 60079-0:2012 • EN 60079-1:2014 • EN 60079-7:2015 • EN 60079-31:2014 • EN 60529:1991
IEC Ex: IEC 60079-0:2011 • IEC 60079-1:2014 • IEC 60079-7:2015 • IEC 60079-15:2010 • IEC 60079-31:2013 • IEC 60529:1989

5 Ambient temperatures in services: sealing washers materials

EPDM seals -40°C ÷ + 100°C (code: **EP**)
 Silicone seals -65°C ÷ + 220°C (code: **SI**)

Cable type

Armoured: Single armoured cable SWA, Alluminium wire armoured cable AWA, Alluminium strip armoured ASA. Single wire braided cable SWB, Steel tape armoured cable STA, Pliable wire armoured cable PWA. Screened flexible wire braided cable CY-SY
Reduced cone available for SWA armoured cables.

6 Available materials

Brass (code: **OT**) • Nickel-plated brass (code: **ON**)
 AISI316L Stainless steel (code: **S6**) • Aluminium (code: **AL**)
 AVP Steel (code: **AVP**)

Available threads

ISO 262 Metrical • ISO 228 • DIN 40430 Pg
 ANSI B1.20.1 NPT • EN 10226 Gk (only for ATEX)

Degree of protection

The cable glands degree of protection is **IP66** or **IP66/68**, 30-meters depth for 7 days according to the IEC EN 60529 standard; the degree of protection IP 68 is obtained by using flat sealing rings on cable glands with cylindrical threads. Without gaskets, the degree of protection is IP 66. If the cable glands with cylindrical or tapered threads are screwed on the threaded hole of an apparatus, in order to guarantee an IP66 or IP66/68 degree of protection, threaded parts must be sealed with Loctite or similar. In order to maintain the IPX8 degree of protection, the cable entry shall be fitted on enclosure witch satisfies an immersion test under 30 meters of water during 7 days. Metric cable glands are made in accordance to EN 62444 Standard.

0 Kit version (code: KIT)

Includes cable glands and the requested complete series of the rubber seals accompanying the size.



EXAMPLE CODE

See page 56

TECHNICAL DRAWING

0 1 2 3 4 4E 5 6 7 8

KIT	RAC.	25.	13.	N25.	N25.	EP.	ON.	OR.	BS
Optional code	Type	Size	Ø C Max	Thread code	Thread code	Seals material code	Material code	Optional code	Optional code
Kit series			Inner seal (10,5 ÷ 13)	See tab. page 57	See tab. page 57	EP-SI	OT-ON-S6 AL-AVP	O-Ring	Reduced cone

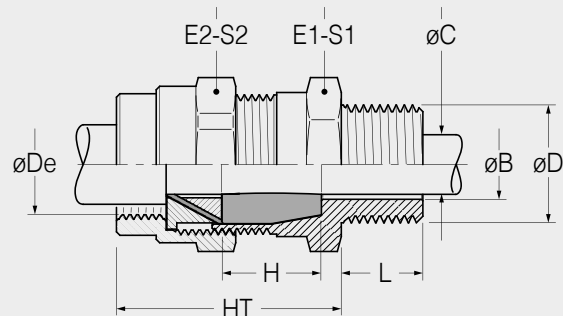

SIZE	Ø C Min - Max Inner seal	ARMOUR RANGE		Ø D - THREADS					Ø De - THREADS					DIMENSIONS						
		Standard cone X*	Reduced cone Y**	Cylindrical			Tapered		Cylindrical			Tapered		Weight	HT	H	E1	S1	E2	S2
				ISO 262	ISO 228	DIN 40430	NPT	EN 10226	ISO 262	ISO 228	DIN 40430	NPT	EN 10226							
16 (EP)	4 ÷ 7 7 ÷ 10																			
16 (SI)	4 ÷ 6 6 ÷ 8 8 ÷ 10	0 ÷ 0,5	0,5 ÷ 0,75	M12x1,5 M16x1,5 M20x1,5	1/4" 3/8" 1/2"	Pg7 Pg9 Pg11 Pg13,5	1/4" 3/8" 1/2"	1/4" 3/8" 1/2"	M16x1,5	3/8"	/	3/8"	/	101	20	24	26	24	26	26
20	5,5 ÷ 8 8 ÷ 10,5 10,5 ÷ 13	0 ÷ 0,5	0,5 ÷ 1,25	M16x1,5 M20x1,5 M25x1,5	1/2" 3/4"	Pg11 Pg13,5 Pg16	1/2" 3/4"	1/2" 3/4"	M20x1,5	1/2"	/	1/2"	/	174	20	30	33	32	35	35
25	8 ÷ 10,5 10,5 ÷ 13 13 ÷ 15,5 15,5 ÷ 18	0 ÷ 0,5	0,5 ÷ 1,25	M20x1,5 M25x1,5	3/4" 1"	Pg16 Pg21	3/4" 1"	3/4" 1"	M25x1,5	3/4"	/	3/4"	/	206	20	35	38	36	39	39
32	13 ÷ 15,5 15,5 ÷ 18 18 ÷ 21 21 ÷ 24	0 ÷ 1	1 ÷ 1,6	M25x1,5 M32x1,5	1"	Pg21 Pg29	1"	1"	M32x1,5	1"	/	1"	/	356	25	42	47	45	49	49
40	21 ÷ 24 24 ÷ 27 27 ÷ 30	0 ÷ 1	1 ÷ 1,6	M40x1,5	1" 1/4	Pg29	1" 1/4	1" 1/4	M40x1,5	1" 1/4	/	1" 1/4	/	431	25	48	53	50	55	55
50	24 ÷ 27 27 ÷ 30 30 ÷ 33 33 ÷ 36	0 ÷ 1	1 ÷ 2	M40x1,5 M50x1,5	1" 1/2	Pg36	1" 1/2	1" 1/2	M50x1,5	1" 1/2	/	1" 1/2	/	568	25	55	60	57	62	62
63	36 ÷ 39 39 ÷ 42 42 ÷ 45	0 ÷ 1	1 ÷ 2	M50x1,5 M63x1,5	2"	Pg42 Pg48	2"	2"	M63 x 1,5	2"	/	2"	/	784	25	68	74	67	73	72
75	45 ÷ 48 48 ÷ 51 51 ÷ 54	0 ÷ 1	1 ÷ 2	M63x1,5 M75x1,5	2" 1/2	Pg48	2" 1/2	2" 1/2	M75x1,5	2" 1/2	/	2" 1/2	/	1124	25	80	86	80	88	88
90a	54 ÷ 58 58 ÷ 62	0 ÷ 2	2 ÷ 2,5	M75x1,5 M90x2	3"	/	3"	3"	M90x2	3"	/	3"	/	2235	30	100	107	100	107	107
90b	60 ÷ 64 64 ÷ 68													1852						

• Standard Threads in bold • Dimensions are in millimeters • Weight in grams (gr) of brass version

* Standard cone X: Suitable for all approved armour cables except SWA cables ** 8 Reduced cone Y: Suitable for SWA cables (code: BS)