

# BXA

type

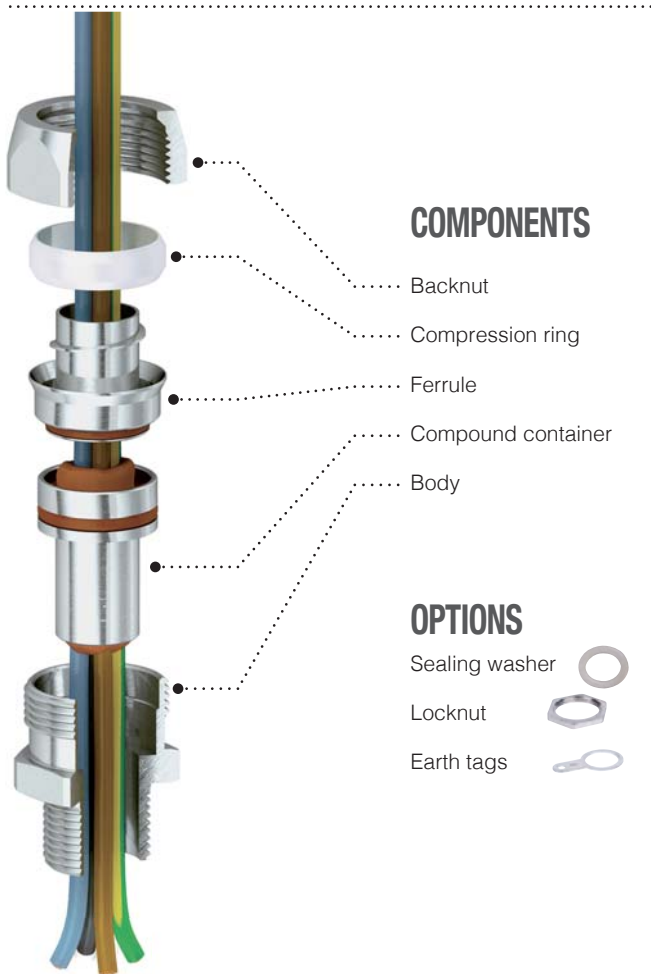

FLAMEPROOF EX D • INCREASED SAFETY EX E • FOR INDOOR & OUTDOOR APPLICATIONS  
FOR UNARMoured CABLES



## 1 Cable glands BXA type (code: BXA)

The cable glands of the BXA series have been designed for the use with a flexible conduit. It has a body which holds the container intended to contain the epoxy resin for sealing the cables. Above the container is positioned an intermediate and body whose upper part has been specially threaded to be coupled with a flexible conduit. A backnut that is going to be screwed onto the body of the cable gland serves to block in position the intermediate body and container.

**Application fields** Surface - Group II • Mines - Group I

### Approvals / Certifications

ATEX: CESI 14ATEX069X  
IEC Ex: IECEx CES 15.0001X  
EAC: RU C-IT.AЯ 45.B.00081

### Protection type

Exd IIC • Ex e II (gas) • Ex tb IIC (dusts) • Ex d I • Ex e I (mines)

### EPL (Equipment protection level)

Zone 1-2: Mb mines • Gb, Gc gas

Zone 21-22: Db Dc combustible dusts

### Execution

Ex d IIC • Ex e II • Ex tb IIC • Ex d I • Ex e I Db  
according to

ATEX: EN 60079-0:2009 • EN 60079-1:2007 • EN 60079-7:2007 • EN 60079-31:2009 • EN 60529:1991

IEC Ex: IEC 60079-0:2011 • IEC 60079-1:2007 • IEC 60079-7:2006 • IEC 60079-31:2008 • IEC 60529:2001

### Ambient temperatures range:

-60°C ÷ +110°C

### Service temperatures range:

-60°C ÷ +130°C

### Cable type

Unarmoured

## 6 Available materials

Brass (code: **OT**) • Nickel-plated brass (code: **ON**)  
AISI316L Stainless steel (code: **S6**) • Aluminium (code: **AL**)

### Available threads

ISO 262 Metrical • ISO 228 • DIN 40430 Pg  
ANSI B1.20.1 NPT • EN 10226 Gk (only for ATEX)

### Degree of protection

The cable glands degree of protection is **IP66** or **IP66/68**, 30-meters depth for 7 days according to the IEC EN 60529 standard; the degree of protection IP 68 is obtained by using flat sealing rings on cable glands with cylindrical threads. Without gaskets, the degree of protection is IP 66. If the cable glands with cylindrical or tapered threads are screwed on the threaded hole of an apparatus, in order to guarantee an IP66 or IP66/68 degree of protection, threaded parts must be sealed with Loctite or similar. In order to maintain the IPX8 degree of protection, the cable entry shall be fitted on enclosure which satisfies an immersion test under 30 meters of water during 7 days. Metric cable glands are made in accordance to EN 62444 Standard.

# DESIGNED FOR SEALING ONE OR MORE CORES



**COMPOUND** Application  
Mixing time  
Gel time  
Full cure time  
Installation

**SOLID**

By hand  
30 min  
-  
4 hours  
Any Orientation

## EXAMPLE CODE

See page 43

1 ..... 2 ..... 4 ..... 6

<b>BXA.</b>	<b>25.</b>	<b>N25.</b>	<b>ON</b>
Type	Size	Thread code	Material code

See tab.  
page 43

<b>OT</b>	Brass
<b>ON</b>	Nickel-plated brass
<b>S6</b>	AISI316L Stainless steel
<b>AL</b>	Aluminium

## TECHNICAL DRAWING

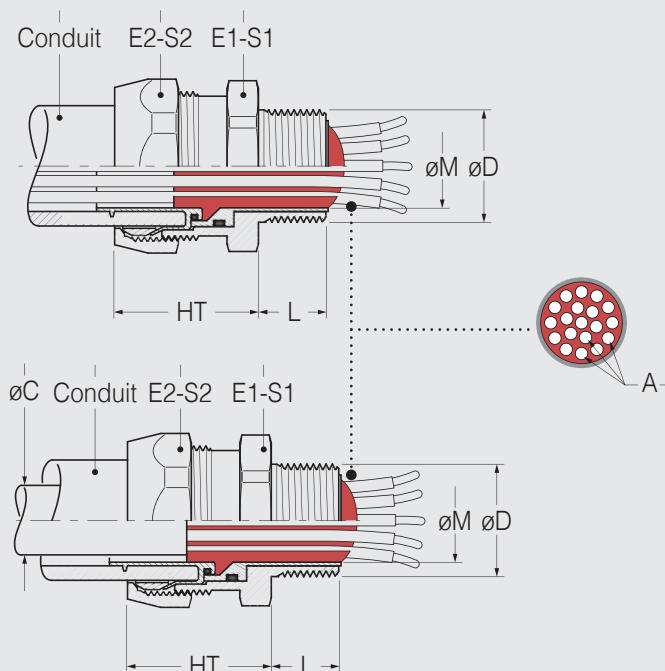

SIZE	Ø D - THREADS					DIMENSIONS									
	Cylindrical			Tapered		Weight	ØC Max Ø ext. conductor	ØM Max over multicores	A Max no conductors	HT	E1	S1	E2	S2	
	ISO 262	ISO 228	DIN 40430	NPT	EN 10226										
16	<b>M16x1,5</b>	<b>3/8"</b>	<b>Pg11</b>	<b>3/8"</b>	<b>3/8"</b>	90	8	9,4	10	24	25	27	26	29	
	M20x1,5	1/2"	Pg13,5	1/2"	1/2"										
20	<b>M20x1,5</b>	<b>1/2"</b>	<b>Pg13,5</b> Pg16	<b>1/2"</b>	<b>1/2"</b>	113	10,5	12,4	15	24,5	28	30,8	30	33	
25	<b>M25x1,5</b>	<b>3/4"</b>	<b>Pg21</b>	<b>3/4"</b>	<b>3/4"</b>	156	14	17,6	30	25,5	34	38	35	38,7	
32	<b>M32x1,5</b>	<b>1"</b>	<b>Pg29</b>	<b>1"</b>	<b>1"</b>	258	18,5	22,8	50	26	43	47	45	50	
40	<b>M40x1,5</b>	<b>1" 1/4</b>	<b>Pg36</b>	<b>1" 1/4</b>	<b>1" 1/4</b>	357	24,5	28	75	27	52	57	55	60	
50	<b>M50x1,5</b>	<b>1" 1/2</b>	<b>Pg36</b>	<b>1" 1/2</b>	<b>1" 1/2</b>	394	29,5	34,5	80	28	55	61	57	63	

• Standard Threads in bold • Dimensions are in millimeters